

OUTBACK RANGER & FURY XC

1/16TH SCALE 4WD READY-TO-RUN TRAIL VEHICLE

UNE VOITURE DE TRAIL 4X4 À L'ÉCHELLE 1/16ÈME PRÊTE À ROULER



INSTRUCTION MANUAL

MANUEL D'INSTRUCTIONS FRANÇAIS – PAGE 9



www.ftx-rc.com





Congratulations on your purchase of the FTX R/C Vehicle.

This scale model has been factory assembled and all electrics installed and set up to make it the easiest possible introduction to the sport of driving RC cars.

WARNING: Read the ENTIRE instruction manual to become familiar with the features of the product before operating. Failure to operate the product correctly can result in damage to the product, personal property and cause serious injury. This is NOT a toy and must be operated with caution and common sense. Failure to operate this product in a safe and responsible manner could result in damage, injury or damage to other property. This product is not intended for use by children without direct adult supervision. It is essential to read and follow all the instructions and warnings in the manual, prior to assembly, set-up or use, in order to operate correctly and avoid damage or serious injury.

Safety Precautions and Warnings

- You are responsible for operating this model such that it does not endanger yourself and others, or result in damage to the product or the property of others.
- This model is controlled by a radio which is possibly subject to interference which can cause momentary loss of control so it is advisable to always keep a safe distance to avoid collisions or injury.
- Age Recommendation: 14 years or over. This is not a toy. This product is not intended for use by children without direct adult supervision.

Carefully follow these directions and warnings, plus those of any additional equipment associated with the use of this model, chargers, ESC and motors, radio etc.

- Never operate your model with low transmitter batteries.
- Always operate your model in an open area away from cars, traffic or people.
- Never operate the model in the street or in populated areas.
- Always keep the vehicle in direct line of sight, you cannot control what you cannot see!
- Keep all chemicals, small parts and anything electrical out of the reach of children.
- Although splash-proof the car and electronics are not designed to be subjected to extended moisture exposure or submersion. To do so will result in permanent damage.
- Avoid injury from high speed rotating parts, gears and axles etc.
- Novices should seek advice from more experienced people to operate the model correctly and meet its performance potential.
- Exercise caution when using tools and sharp instruments.
- Do not put fingers or any objects inside rotating and moving parts.
- Take care when carrying out repairs or maintenance as some parts may be sharp.
- Do NOT touch equipment such as the motor, electronic speed control and battery, immediately after using your model because they can generate high temperatures.
- Always turn on your transmitter before you turn on the receiver in the car. Always turn off the receiver before turning your transmitter off.
- Keep the wheels of the model off the ground, and keep your hands away from the wheels when checking the operation of the radio equipment.
- Prolong motor life by preventing overheat conditions. Undue motor wear can result from frequent turns, rapid change of direction forwards/backwards, continuous stop/starts, pushing/pulling objects, driving in deep sand and tall grass, or driving continuously up hill.



REQUIRED EQUIPMENT FOR OPERATION

1. Tools required for building and maintenance:

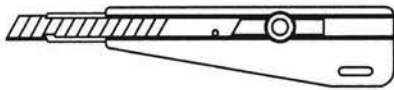

● Hobby knife

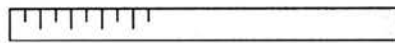

● Precision ruler

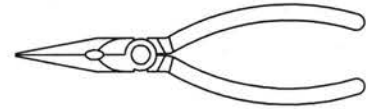

● Needle nose pliers

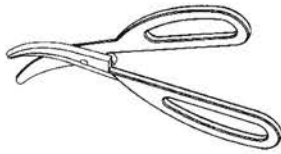

● Lexan scissors

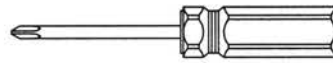
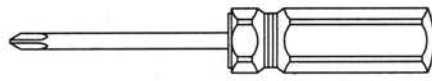

● Flat and Philips screwdriver

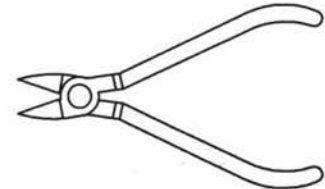

● Wire cutters

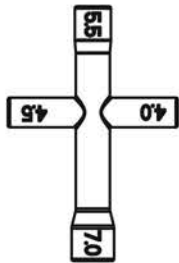

● Cross wrench

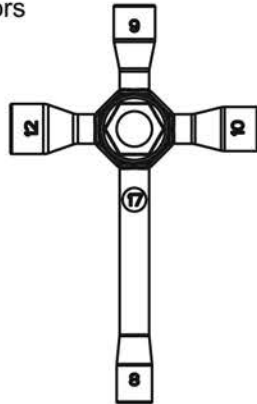

● Cross wrench



● CA glue & rubber cement



● Thread locking compound



1.5mm



2.0mm



2.5mm

● Hex wrench

WARNING!

Do not use a power screw driver to install screws into nylon or plastic materials. The fast locking may heat up the screws being installed that may break the molded parts or strip the threads during installation.

2. Additional items needed for operation:

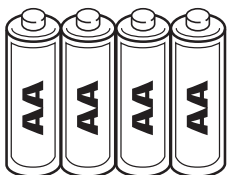

4 pcs AA Alkaline Batteries

IMPORTANT!

Check that all screws and nuts are tight before each use.



GETTING TO KNOW YOUR TRANSMITTER

RECEIVER & SPEED CONTROL WIRING DIAGRAM

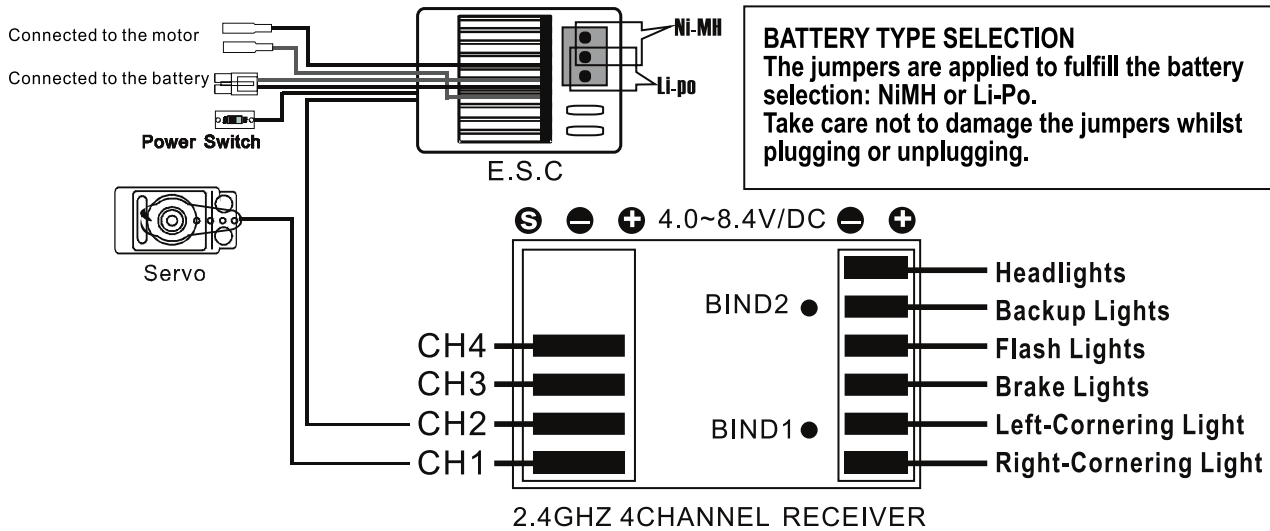

BATTERY TYPE SELECTION

The jumpers are applied to fulfill the battery selection: NiMH or Li-Po.
Take care not to damage the jumpers whilst plugging or unplugging.

TRANSMITTER/LIGHT SET INSTRUCTION

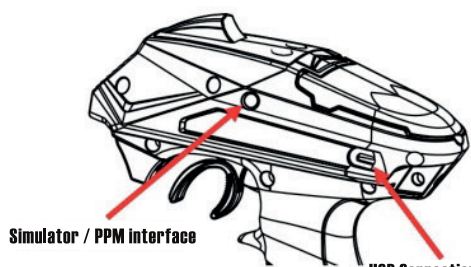

Battery Installation:

1. Open the battery compartment cover.
2. Insert 4 AA fully charged batteries or 2S Li-Po batteries with correct polarity.
(No response if battery polarity reversed.)
3. Replace battery compartment cover.

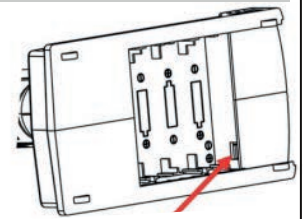

The battery socket is equipped with anti-reverse insertion function, wrong polarity connection will not burn the transmitter.

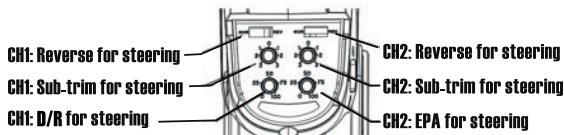

Binding Process:

1. Press the receiver button and the LED indicator will flash fast indicating it is entering bind mode.
2. Turn on transmitter. The receiver will automatically look for the nearest transmitter signal.
3. Once binding is stop flashing and remain on.

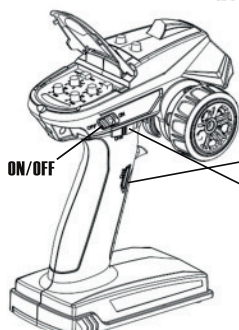
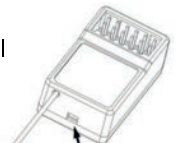

Once move the steering wheel four times in clockwise, all the lights will turn on steady
Once move the steering wheel four times in counterclockwise, all the lights will turn off.

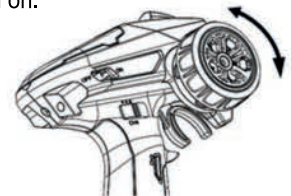

CH3 is for front and rear cornering light.

Turn on the switch, the cornering light will now flash steady
Turn off the switch, the cornering light will only indicate the cornering signal.

CH4 is for headlight switch.

Push the CH4 button to the centre position, the flashing light will flash (white).
Push the CH4 button to the maximum forward position, and the flashing light will be steady on.
Set the button in to first position and only the blue outer ring light illuminates at full power.

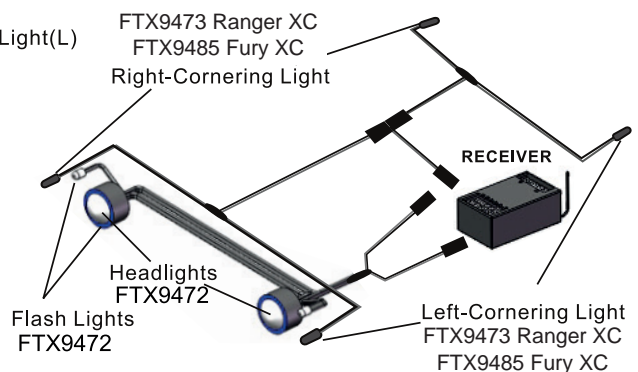
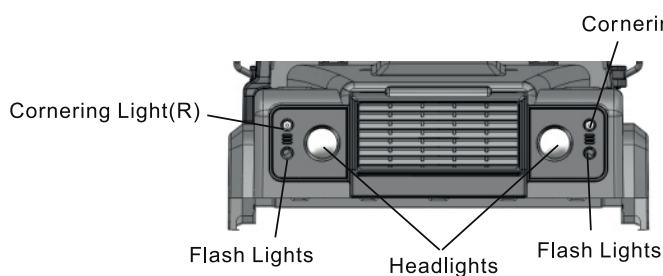



RUNNING YOUR CAR

1. TURNING ON THE RECEIVER OF YOUR CAR

The ESC Receiver switch is located under the side plate of the model. Switch on the ESC/Receiver Switch as shown in the picture.

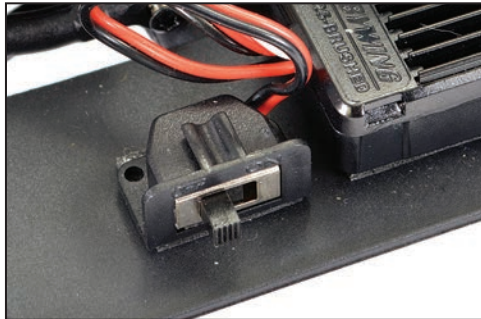

2. TURN ON THE RADIO CONTROLLER

Switch on the power switch on the radio controller. Your radio is bound with your car automatically.



3. CHECK STEERING PERFORMANCE

CENTRE

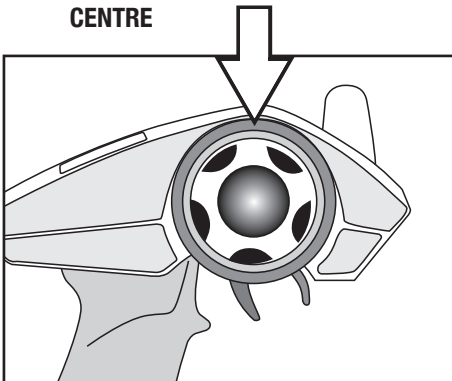

1. To keep the car running straight, keep the steering wheel centered.

TURN RIGHT

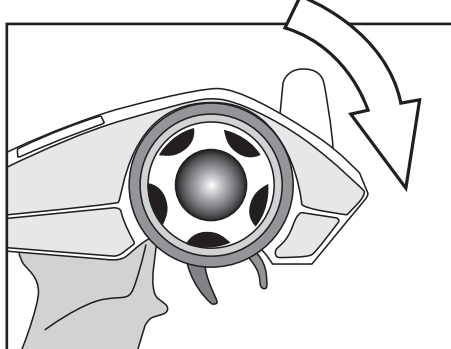

2. Turn the steering wheel to the right to allow the car to right.

TURN LEFT

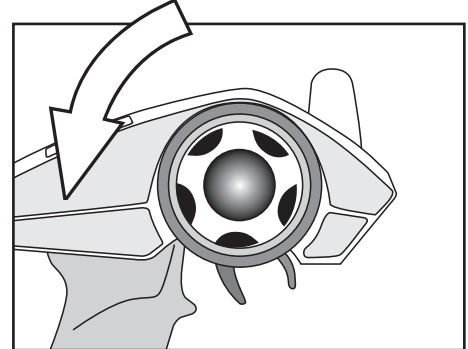

3. Turn the steering wheel to the left to allow the car to turn to the left.

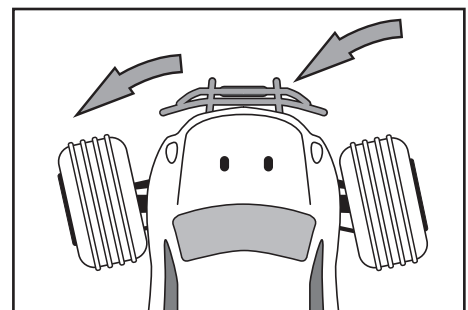
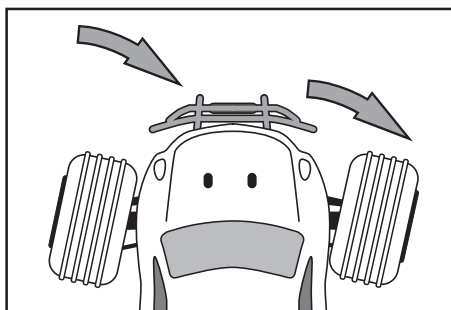
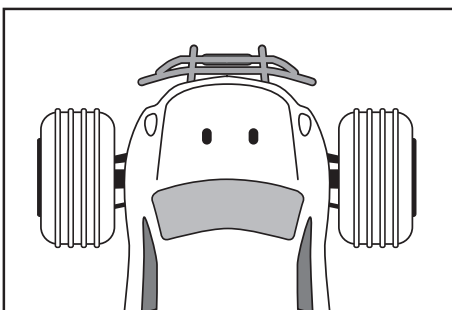

4. CHECK TRIGGER RESPONSE

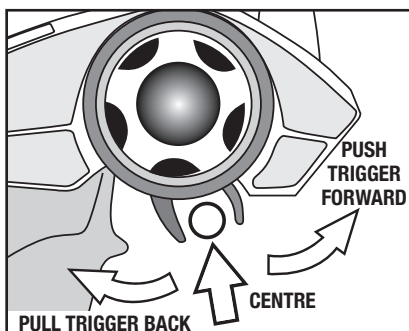

PLEASE NOTE: THE MODEL SWITCHES BETWEEN FORWARD AND REVERSE INSTANTLY FOR SLOW SPEED MANEOUVABILITY. EXCESSIVE USE OF THIS FEATURE CAN CAUSE TRANSMISSION AND ESC DAMAGE.

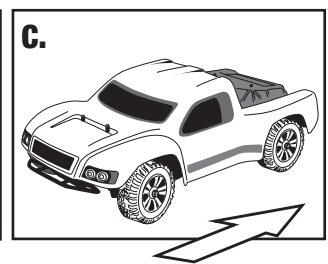
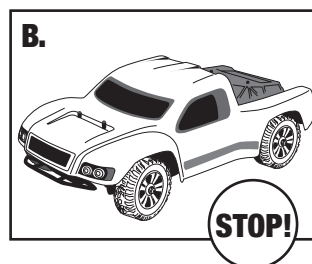
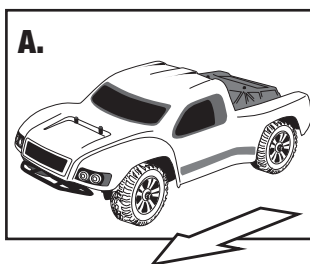

A. Pull the trigger back to accelerate, release it to decelerate.
B. To stop running your car, release the trigger to neutral.
C. Pushing the trigger forward activates reverse.



RUNNING YOUR CAR

5. TUNING THE STEERING TRIM

STEERING TRIM DIAL

Gently pull the trigger to allow your car to run slowly. Meantime, tune the steering trim to allow the front wheels to be aligned by rotating the dial.

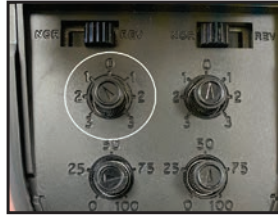

STEERING

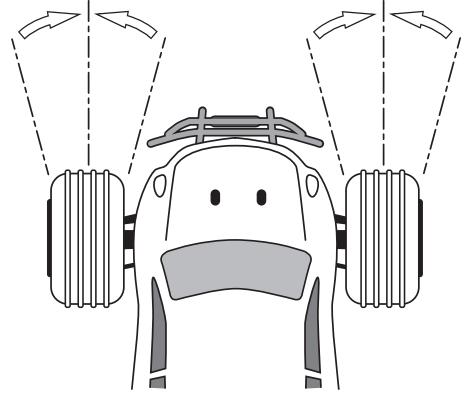

6. TUNING THE THROTTLE TRIM

THROTTLE TRIM DIAL

Throttle Trim is used to set the idle speed of the car, by rotating the dial.

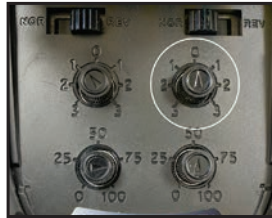

THROTTLE TRIM

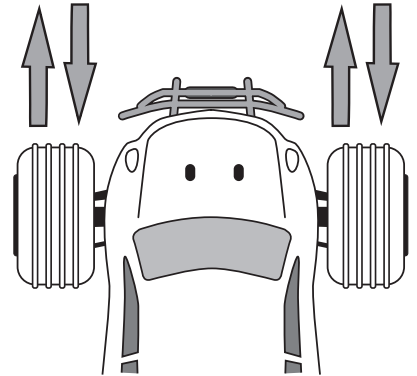

7. TO TUNE THE STEERING AND THROTTLE DUAL RATE CONTROL

STEERING D/R DIAL

The D/R controls the amount of servo travel. You should adjust this to give maximum steering without any extra strain on the servo.

Set it to minimum first and then slowly adjust until full steering is achieved.



STEERING D/R

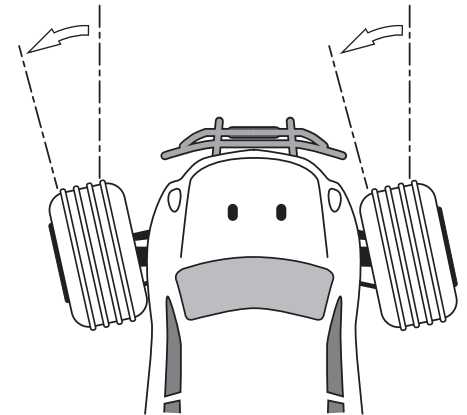

THROTTLE D/R

With this dial you can adjust the the maximum power output from your speed control.

8. STEERING/THROTTLE REVERSE

STEERING REVERSE:

To reverse the direction of servo travel for steering (CH1).

THROTTLE REVERSE:

Allows you to electronically switch the direction that the motor operates in relation to the throttle trigger. For example, if you pull the throttle trigger to accelerate forward but the model goes in reverse, flip the Throttle Reverse switch to make the model accelerate forward.





CHARGING

8 CHARGING/INSTALLING THE BATTERY

- Always store your model with the battery pack unplugged and removed.
- Always charge your battery away from the vehicle. The included USB charger will take approximately 1.5–2 hours to charge a discharged battery.
- When charging the Red LED will be solid.
- When the battery is fully charged the Green LED will be solid.

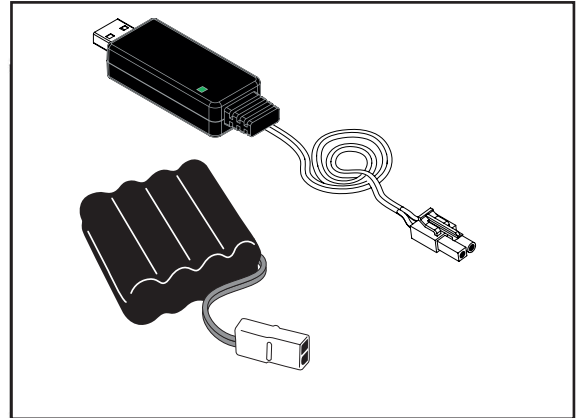

- The battery will become warm to touch when charged, but not hot.
- If the battery is hot, stop charging immediately. Disconnect the battery from the charger as soon as the charger LED turns green.

9 NOTES ON BATTERY USE

- Always allow the battery cool after use, before recharging.
- Always inspect the battery before charging.
- Any bare wires, split heat shrink or leakage is a sure sign of abuse.
- Never attempt to charge dead or damaged batteries.
- Do not disassemble the battery or cut the connector wires.
- If the battery connector gets hot enough to melt there is most likely a serious problem with your model, driveline, battery wires or speed controller. Find and correct the problem before installing another charged battery pack.
- NEVER charge the battery unattended in case of overcharging, you need to be able to monitor the battery during charging.
- Charge away from flammable objects and on a non-flammable surface in case the battery becomes too hot.

(Note: Your model is already bound from the factory)



Getting Started

Switch on transmitter. Hold vehicle clear of the ground, connect battery pack and switch on receiver. Bind the Transmitter and receiver if required.

Test the transmitter to check control of the vehicle with wheels off the ground. Start driving slowly and if the vehicle does not go straight, adjust steering trim dial on Transmitter. For the very first run use the throttle gently, to gradually bed in the motor brushes and help the driver become accustomed to the vehicles behaviour and controls.

PLEASE NOTE:

Although the electronics are waterproof the rest of car can be subjected to damage if running in excessively wet or submerged conditions.

After Run.

Switch off the receiver power, switch off the transmitter and lower the aerial. Disconnect the battery and remove it from the vehicle, allow it to cool before recharging. If you have a second charged battery all ready to use, still allow the vehicle to cool slightly before continuing.

Regular maintenance.

Frequently check the whole vehicle for loose or missing fixings. Use thread lock on any replacement screws into metal threads.

Frequently check rotating parts are free from grass, string etc. that might bind their motion and over stress the motor or speed controller. Remove the wheels occasionally and check behind the mounting hex for obstructions or anything that might have been wrapped around the axle and caused extra drag.

Shock absorbers will wear prematurely if used in dirty dusty conditions. Replace oil and seals as required to keep a smooth dampening action.

Warranty

Due to the nature of this product and potential use FTX warrants it to be free of material and workmanship defects when new. FTX will at its sole discretion repair or replace defective components free of charge within 30 days from date of purchase. This warranty does not cover wear and tear, crash or impact damage, modifications, component water damage failure to perform maintenance or damage from improper use. Proof of purchase date will be required to action any warranty claims. In no case shall FTX's liability exceed the original cost of the purchased kit.

Trouble shooting guide.

SHORT RUNTIME:	SLUGGISH ACTION:	MOTOR/ESC OVERHEAT:	MOTOR SPINS BUT VEHICLE REFUSES TO MOVE:	POOR RANGE OR FAILS TO OPERATE:
Battery damaged/not charged Motor dirty or brushes worn Drivetrain binding	Motor dirty or brushes worn Bind in drive train Battery running low on power	Over-gearred Binding transmission. Seized axle bearing. Motor binding	Gears damaged. Gears loose on shaft. Drive shaft broken or missing.	Transmitter batteries low Vehicle Battery Low. Transmitter switched off Transmitter/receiver aerial not extended. ESC switched off or battery not connected. Loose connectors/wires.

Instructions for disposal.

Environmental Protection Notes & WEEE

The crossed-out wheeled bin symbol shown here, which may be found on the product itself, in the operating instructions or on the packaging, is in accordance with the Waste Electrical and Electronic Equipment (WEEE) Directive. Individual markings indicate which materials can be recycled and re-used. You can make an important contribution to the protection of our common environment by re-using the product, recycling the basic materials or recycling redundant equipment in other ways.

When this product comes to the end of its useful life, you must not dispose of it in the ordinary domestic waste. Many electrical items that we throw away can be repaired or recycled. Recycling items helps to save natural resources and also reduces the environmental and health impacts that are linked with sending electrical goods to landfill. The correct method of disposal is to take it to your local collection point for recycling electrical and electronic equipment. You can go to recycle-more.co.uk for details of locations.

Alternatively FTX can offer our customers free take-back of their WEEE on a like-for-like basis when they buy a new Electrical or Electronic product from us. For example, if a customer bought a new radio system from us or a dealer, we would accept their old radio and prevent it going into a landfill site by disposing of it safely. Customers must return their old WEEE item to us within 28 days of purchasing their new item.

Remove batteries from your device and dispose of them at your local collection point for batteries. If you don't know the location of your nearest disposal centre, please enquire at your local council office.



CML Distribution, Saxon House, Saxon Business Park, Hanbury Road,
Bromsgrove, B60 4AD.

WEE/GB4215VX





Félicitations pour votre achat du FTX R/C Vehicle.

Ce modèle réduit a été assemblé en usine et tous les appareils électriques installés et configurés pour en faire l'introduction la plus simple possible au sport de la conduite de voitures RC.

Attention: lisez l'intégralité du manuel pour exploiter au mieux la voiture et éviter des dommages mécaniques ou corporels. Ce modèle n'est pas un jouet, il doit être manipulé avec précaution. Utilisé dans de mauvaises conditions, ce modèle peut causer des dommages.

Ce modèle n'est pas fait pour être utilisé par un enfant sans la surveillance directe d'un adulte. Il est essentiel de lire et de suivre les instructions et les recommandations de ce manuel pour entretenir et faire évoluer votre modèle dans de bonnes conditions.

Mesures de sécurité:

- Vous êtes responsable lors de l'évolution de ce modèle, veillez à ne pas vous mettre en danger, à mettre en danger le modèle ou la propriété d'autrui.
- Ce modèle radiocommandé peut être perturbé par d'autres sources d'onde radio, ce qui peut entraîner la perte momentanée du contrôle de la voiture.
- Age recommandé : 14 ans, ceci n'est pas un jouet, ce produit n'est pas fait pour être utilisé par un enfant sans surveillance.

Suivez consciencieusement les instructions suivantes :

- Ne jamais évoluer avec des batteries d'émission faibles
- Toujours évoluer dans une zone dégagée, loin de la circulation et de la foule
- Ne jamais évoluer dans une rue ou un endroit fréquenté
- Toujours garder le modèle dans son champ de vision
- Gardez hors de portée des enfants tous les composants de petite taille, électriques ou chimiques
- Tenez le modèle hors de portée de l'eau (la rouille peut causer des dommages irréversibles au modèle)
- Faites attention aux pièces en rotations, axes, pignons etc.
- Les débutants doivent prendre conseil auprès de personnes plus expérimentées
- Faites attention lors de l'utilisation des outils
- Attention à ne pas mettre les doigts ou d'autres parties du corps en contact avec les pièces en rotation
- Faites attention lors du transport, de la maintenance ou de la réparation, certaines pièces peuvent être coupantes.
- **NE JAMAIS** toucher les composants tels que le moteur, le variateur ou les batteries après utilisation, ces pièces peuvent être chaudes
- Lorsque vous changez de fréquence d'émission assurez-vous que les quartz de fréquence sont bien positionnés (RX pour récepteur et TX pour l'émetteur)
- Toujours éteindre en premier la voiture avant l'émetteur
- Vérifiez le bon fonctionnement de la voiture les roues dans le vide (en prenant les précautions nécessaires)
- Prolongez la durée de vie du moteur en le préservant de la surchauffe (la durée de vie du moteur dépend aussi de la fréquence de roulage, des changements rapide de direction avant/arrière, des conditions de roulage difficiles poussière/boue des utilisations abusives tirer/pousser des objets)



EQUIPMENTS REQUIS POUR LA MAINTENANCE:

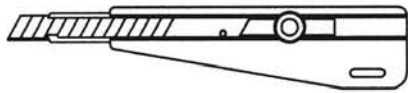

● Cutter



● Règle

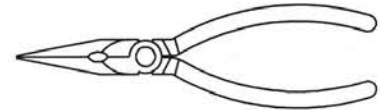

● Pince

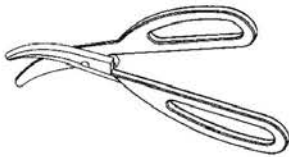

● Ciseaux à lexan

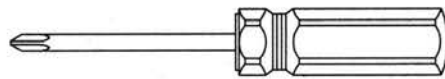

● Tournevis plats et cruciformes

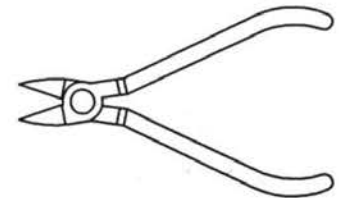
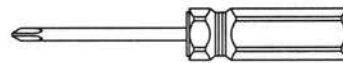

● Pince coupante

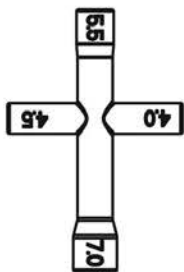

● Clé

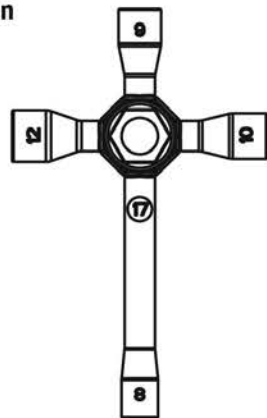

● Colle à pneu



● Frein filet



● Clé Allen

ATTENTION: L'utilisation d'une visseuse électrique pour la maintenance pourrait endommager l'emprunte des vis ou casser des pièces du modèle.

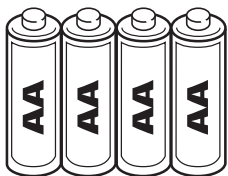

4 piles alcalines AA pour l'émetteur

IMPORTANT: Veuillez vérifier le serrage de chaque vis et écrous avant l'utilisation du modèle.



FAMILIARISEZ VOUS AVEC VOTRE SYSTÈME RADIO 2.4 GHZ

SCHÉMA DES BRANCHEMENTS DU CONTRÔLEUR DE VITESSE

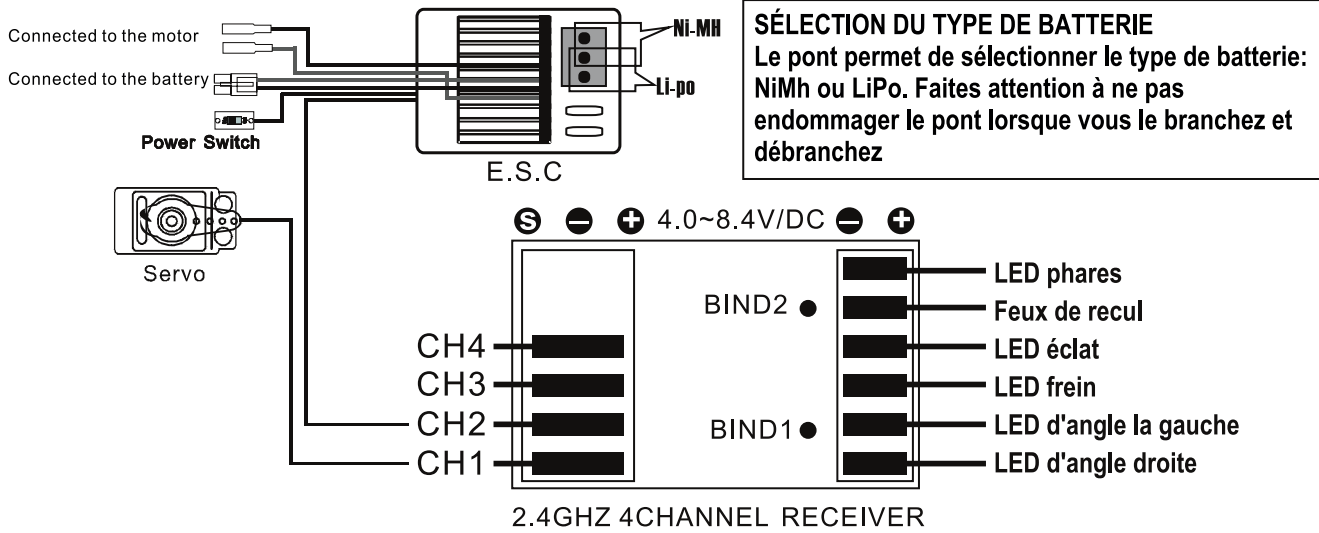

FAMILIARISEZ VOUS AVEC VOTRE SYSTÈME RADIO 2.4 GHZ

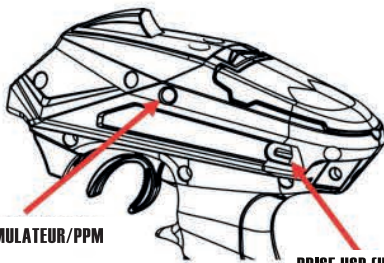

PRISE SIMULATEUR/PPM

MONTAGE DES PILES DANS LA TÉLÉCOMMANDE

1. Appuyez sur le couvercle du compartiment batterie et faites-le glisser dans le sens de la flèche afin de l'enlever.
2. Installez les 4* piles AA (ou NiCd ou NiMh) comme indiqué sur le compartiment batterie. Assurez-vous de bien respecter les polarités (+ et -), sinon la télécommande ne fonctionnera pas.
3. Remontez le couvercle du compartiment batterie en place et faites-le glisser dans le sens inverse

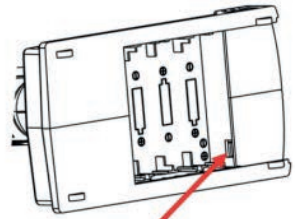

PRISE POUR LES LIPO 2S

INTERRUPTEUR D'INVERSION DE LA DIRECTION (VOIE 1)
RÉGLAGE DES TRIMS DE LA DIRECTION (VOIE 1)
RÉGLAGE DU DUAL/RATE DE LA DIRECTION (VOIE 1)

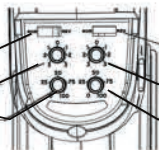

INTERRUPTEUR D'INVERSION DES GAZ (VOIE 2)
RÉGLAGE DES TRIMS DES GAZ (VOIE 2)
RÉGLAGE DU DUAL/RATE DES GAZ (VOIE 2)

INTERRUPTEUR D'INVERSION DES GAZ (VOIE 2)
RÉGLAGE DES TRIMS DES GAZ (VOIE 2)
RÉGLAGE DU DUAL/RATE DES GAZ (VOIE 2)

PROCÉDURE DE LIAISON (BIND)

1. Appuyez sur le bouton du récepteur. La LED va alors clignoter rapidement indiquant qu'il est rentré dans le mode bind.
2. Allumez la télécommande. Le récepteur recherche automatiquement la télécommande la plus proche
3. Une fois la procédure effectuée, la LED arrête de clignoter et reste allumée



LED D'INDICATION

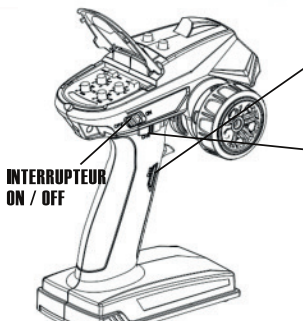

CH3 La voie CH3 est dédiée pour la LED d'angle à l'avant et l'arrière. Mettez l'interrupteur sur ON afin de que la LED d'angle clignote régulièrement. Mettez l'interrupteur sur OFF afin de que la LED d'angle clignote seulement lors des virages.

CH4 La voie CH4 est dédiée au phare principal. Poussez l'interrupteur de la voie CH4 dans sa position centrée afin que le phare clignote en blanc. Poussez l'interrupteur de la voie CH4 dans sa position avant afin que le phare reste allumé en blanc. Mettez l'interrupteur de la voie CH4 dans sa position primaire afin que la partie extérieure du phare s'allume en bleu

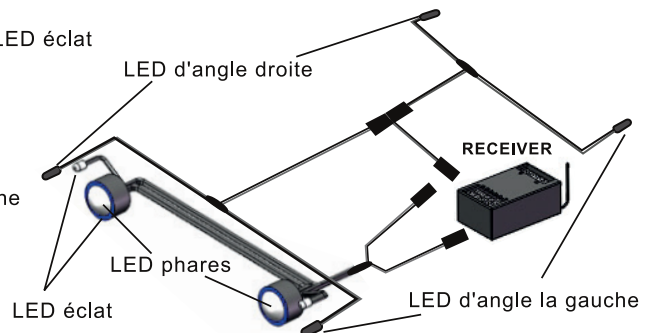
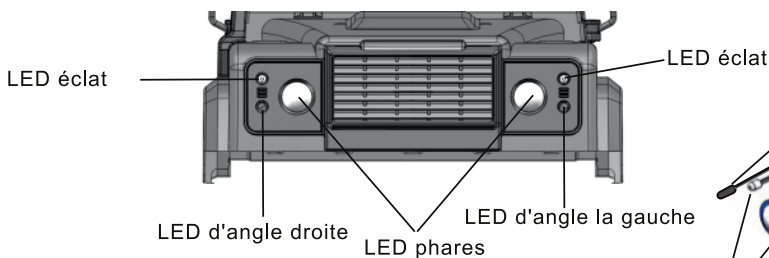
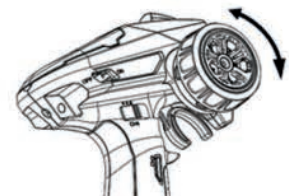



GESTION DE VOTRE VOITURE

1. METTRE SUR ON INTERRUPTEUR

L'ensemble variateur/ récepteur se situe sur ON comme montré sur la photo.

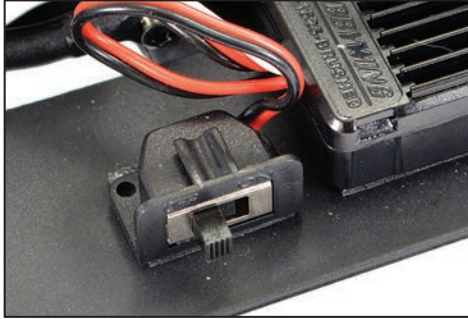

2. METTRE LA RADIO SUR ON

Mette le bouton d'allumage de la radio sur ON. Votre voiture est automatiquement appairer avec votre radio.



3. ASSURE UNE BONNE PERFORMANCE DE PILOTAGE

CENTRE

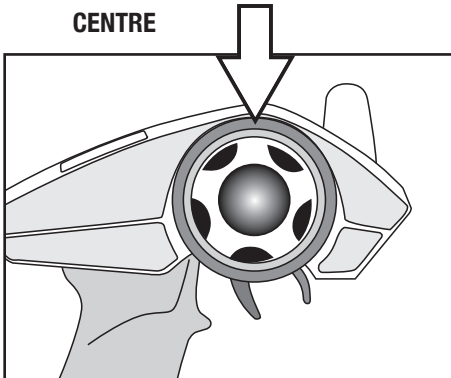

1. Pour que la voiture aille droite ne pas tourner le volant (le laisser au centre).

TOURNE À DROITE

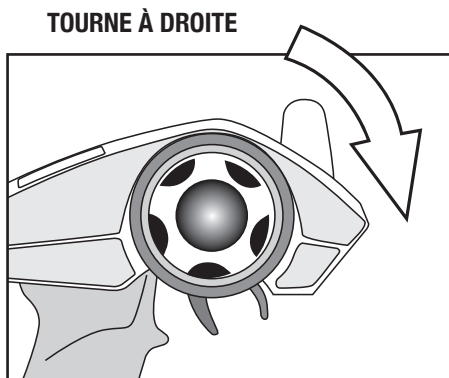

2. Tourner à droite pour permettre à votre d'aller à gauche.

TOURNE À GAUCHE

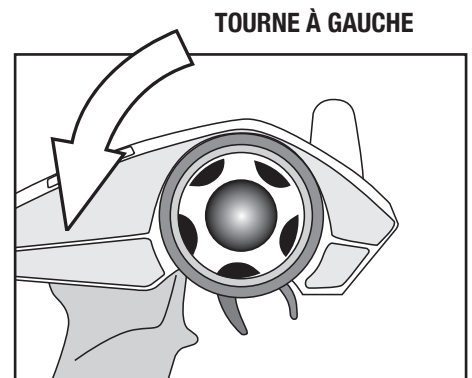

3. Tourner à gauche pour permettre à votre voiture d'aller à droite.

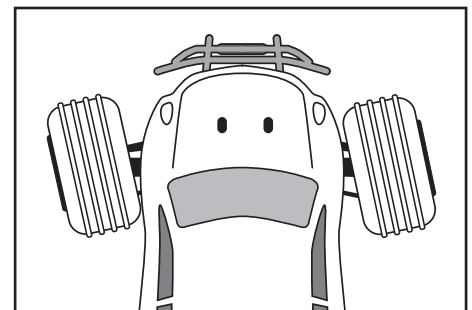
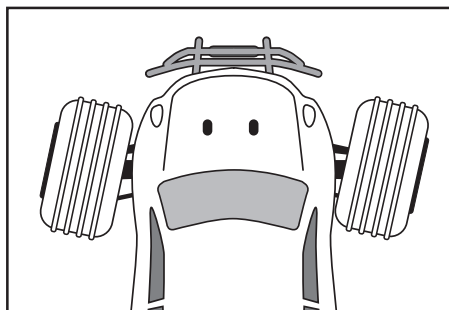
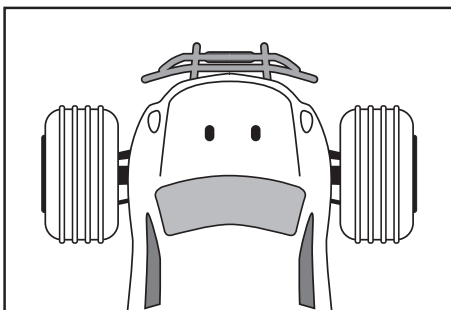

4. VÉRIFIER LA REEONSE DE LA GACHETTE

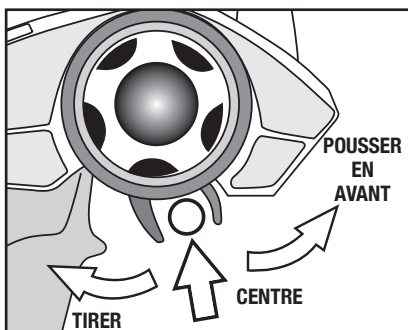

S'IL VOUS PLAÎT NOTEZ :

LE MODÈLE PASSE ENTRE LA MARCHÉ AVANT ET ARRIÈRE INSTANTANÉMENT POUR UNE MANŒUVRABILITÉ À FAIBLE VITESSE. UNE UTILISATION EXCESSIVE DE CETTE FONCTIONNALITÉ PEUT ET VA ENDOMMAGER LA TRANSMISSION ET L'ESC.

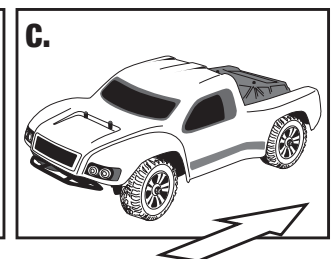
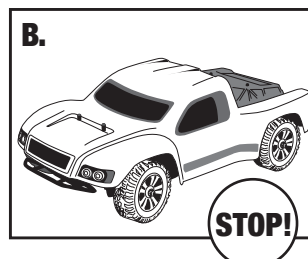
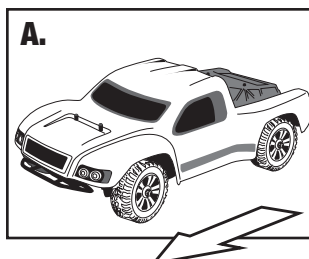

A. Tirer la gâchette en arrière pour accélérer? La lâcher pour décélérer et la pousser pour freiner.

B. Pour arrêter la voiture, lâchette jusqu'au neutre.

C. Pousser la gâchette vers l'avant active la marche arrière.



GESTION DE VOTRE VOITURE

5. POUR MODIFIER LE TRIM DE DIRECTION

Placer la voiture sur le stand avec les roues qui ne touchent pas le sol, puis régler le Trim de direction pour aligner les roues avant.



TRIM DE DIRECTION

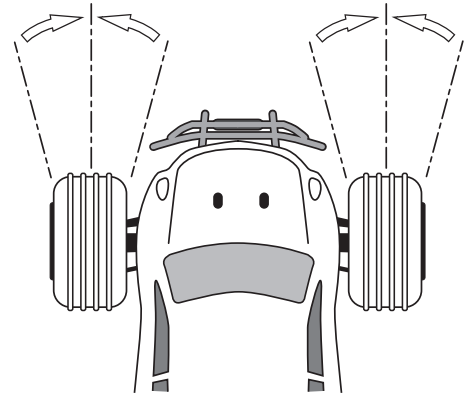

6. POUR MODIFIER LE TRIM DE GAZ

Trim des gaz est utilisé pour régler la vitesse de ralenti.



TRIM DE GAZ

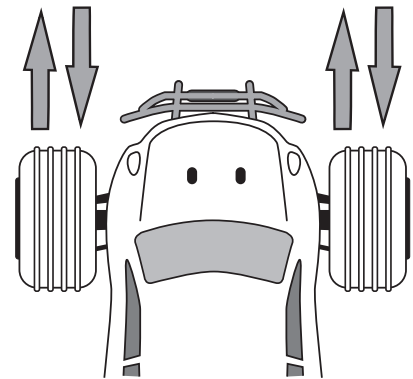

7. POUR MODIFIER LA COURSE (DIR) DE LA DIRECTION

Ce réglage ajuste la course du servo de direction. Pousser le bouton en avant pour un maximum de directivité. Tirer en arrière pour réduire la course du servo.



DIRECTION D/R

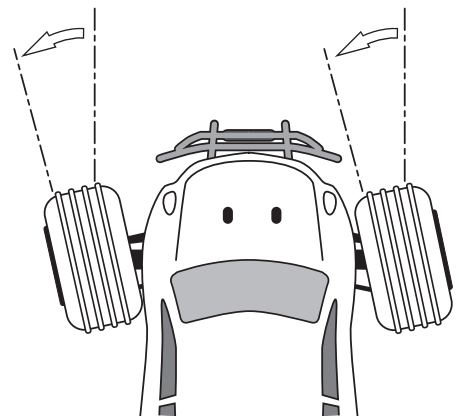

8. REG/AGE DES REVERSES DIRECTION/GAZ

DIRECTION REVERSE:

Cela permet électroniquement d'inverser le sens de rotation du servo. Par exemple si vous si vous tournez le volant à droite.

GAZ REVERSE:

Cela vous permet de changer électroniquement la direction dans laquelle le moteur opère en relation avec la gâchette des Gaz. Par exemple, si vous poussez la gâchette pour accélérer en avant, mais le model va en arrière, inverser le Gaz Reverse permettra au model d'accélérer en avant.





CHARGE

8. CHARGEMENT ET MONTAGE DE LA BATTERIE

- Stockez toujours votre voiture avec la batterie débranchée et enlevée
- Chargez toujours votre batterie en dehors de la voiture. Le chargeur USB inclus met environ 1.5h à 2h pour charger la batterie lorsqu'elle est déchargée.
- Pendant la charge la LED rouge reste allumée
- Lorsque la batterie est chargée, le LED verte restent allumées.
- La batterie peut légèrement chauffer pendant la charge, mais elle ne doit pas être chaude.
- Si la batterie est chaude, arrêtez immédiatement la charge. Débranchez alors la batterie du chargeur dès que la LED du chargeur devient verte.

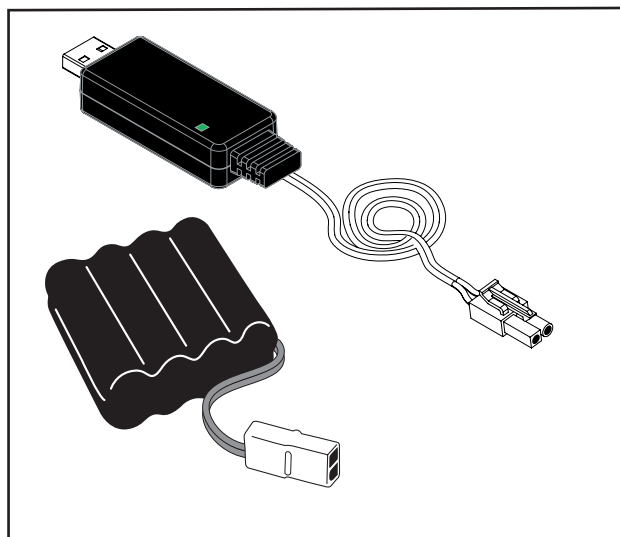

9. NOTES SUR L'UTILISATION DE LA BATTERIE

- Laissez toujours la batterie refroidir après son utilisation avant de la recharger.
- Inspectez toujours la batterie avant de la charger
- Tout fil dénudé, connecteur coupé ou fuite montre une mauvaise utilisation de la batterie
- N'essayez jamais de charger une batterie endommagée ou morte
- Ne démontez pas la batterie et/ou ne coupez pas les câbles
- Si la connectique de la batterie devient tellement chaude qu'elle fond, cela indique qu'il y a un problème important avec votre voiture, la transmission, les câbles de la batterie ou le contrôleur de vitesse. Trouvez alors l'origine du problème et corrigez-le avant de monter une autre batterie
- Ne chargez jamais la batterie sans la surveiller en cas de surcharge, vous devez pouvoir monitorer la charge à tout moment
- Chargez la batterie éloignée de tout matériaux inflammables sur une surface non inflammable dans le cas où la batterie deviendrait trop chaude.

(Remarque: votre modèle est déjà lié de l'usine)



En route

Dépliez l'antenne passez sur ON la radio, tenez la voiture les roues en l'air, connectez les batteries puis allumez la voiture. Testez la voiture les roues en l'air pour vous assurer de son bon fonctionnement puis poser la voiture au sol et testez doucement son fonctionnement. Si la voiture ne va pas droit ajustez le trim de direction. Lors de la première utilisation accélérez doucement pour vous familiariser avec l'utilisation de la voiture.

S'IL VOUS PLAÎT NOTE

IMPORTANT : Veuillez noter que ce véhicule n'est pas étanche et ne doit pas être exécuté dans des conditions mouillées ou humides où l'humidité pourrait pénétrer dans l'électronique.

Arrêt du modèle

Eteignez l'interrupteur du récepteur (voiture), éteignez ensuite l'interrupteur de la radio-commande puis repliez l'antenne.

Débranchez ensuite les batteries et retirez celles-ci de la voiture.

Laissez les batteries refroidir avant des les recharger. Si vous possédez une seconde batterie déjà chargée, laissez le véhicule refroidir quelques minutes avant d'installer cette deuxième batterie.

Entretien.

Vérifiez souvent que les vis ne manquent pas ou ne sont pas desserrées. Utilisez Threadlocker pour tout remplacement de vis en métal. Vérifiez que les pièces rotatives sont libres (herbe, pierre, etc.). Si ces pièces ne sont pas libres, cela peut les endommager ou usent le moteur ou l'entraînement. Retirez les roues et vérifiez que rien n'a glissé derrière l'hexagone de roue et empêche une bonne liberté de transmission. Les amortisseurs s'useront plus rapidement si vous roulez conditions poussiéreuses, remplacez l'huile ainsi que les joints pour maintenir un bon amortissement. Vérifiez souvent que les vis ne manquent pas ou ne sont pas desserrées. Utilisez Threadlocker pour tout remplacement de vis en métal. Vérifiez que les pièces rotatives sont libres (herbe, pierre, etc.). Si ces pièces ne sont pas libres, cela peut les endommager ou usent le moteur ou l'entraînement. Retirez les roues et vérifiez que rien n'a glissé derrière l'hexagone de roue et empêche une bonne liberté de transmission. Les amortisseurs s'useront plus rapidement si vous roulez conditions poussiéreuses, remplacez l'huile ainsi que les joints pour maintenir un bon amortissement.

Solutions aux problèmes:

Durée de roulage très courte:	Vitesse lente:	Le moteur ou le variateur surchauffe:	Le moteur tourne mais la voiture n'avance pas:	Une portée courte ou aucun contrôle de la voiture:
Les batteries sont endommagées ou mal chargées.	Le moteur est sale ou les charbons usés.	La transmission n'est pas libre	La transmission est abîmée.	Les piles de la télécommande sont vides, les batteries de la voiture sont vides, l'antenne n'est pas dépliée, un fil est débranché, l'électronique est endommagée.
Le moteur est sale ou les charbons usés.		Le moteur est endommagé.	Le slipper est desserré, un cardant est cassé ou manquant.	

Garantie

De part la nature de ce produit et l'utilisation potentiel, FTX garanti qu'il n'a pas défaut lorsque le modèle est neuf. FTX s'engage à réparer ou remplacer les composants défectueux gratuitement dans un délai de 30 jours à compter de la date d'achat. Cette garantie ne couvre pas l'usure normale, l'accident ou l'impact, les modifications, les dégâts des eaux (appareil n'étant pas étanche) le manque d'entretien ou de dommages causés par une mauvaise utilisation. La preuve de la date d'achat sera nécessaire lors des réclamations de garantie.

Instructions pour la mise au rebut.

Ce produit ne doit pas être jeté avec les autres déchets. L'utilisateur doit le déposer dans un point de collecte et de recyclage des déchets. Pour plus d'informations sur l'endroit où vous pouvez déposer vos déchets, s'il vous plaît contacter votre municipalité, ou bien où vous avez acheté le produit.



CML DISTRIBUTION, SAXON HOUSE, SAXON BUSINESS PARK,
HANBURY ROAD, BROMSGROVE, B60 4AD.















WEE/GB4215VX





FTX OUTBACK FURY XC & RANGER XC PARTS LISTING











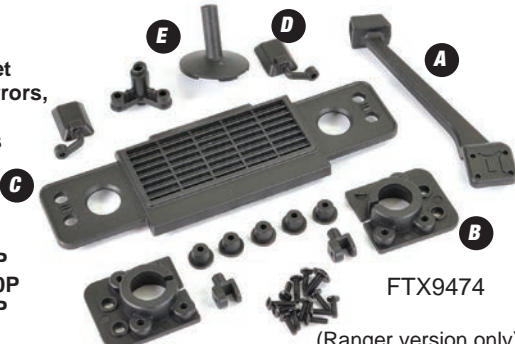









Spare Part

<p>Main Chassis Set</p>  <p>FTX9450</p>	<p>A-Front Lower Link, B-Front Upper Link, C-Rear Lower Link,</p>  <p>D-Rear Upper Link, E-Steering Link, F-Servo Link, G-Body Post</p> <p>FTX9451</p>	<p>Front/Rear Axle Housing Set</p>  <p>FTX9452</p>	
<p>Front & Rear Bumper Set (Ranger version only)</p>  <p>FTX9453</p>	<p>A-Motor Gear Box, B-Front Hub Set, C-Motor Mount</p>  <p>FTX9454</p>	<p>A-Telescopic Main Drive Shaft Set, B-Wheel Hex with Pin, C-Servo Hex, D-Pin 1.5x10</p>  <p>FTX9455</p>	<p>A-Motor Gear/Drive Gear, B-Motor Gear Axle, C-Drive Shaft, D-Pin 2x9</p>  <p>FTX9456</p>
<p>Front Drive Shaft</p>  <p>FTX9457</p>	<p>Rear Drive Shaft</p>  <p>FTX9458</p>	<p>Axle Main Outdrive</p>  <p>FTX9459</p>	<p>Wheel Axle</p>  <p>FTX9460</p>
<p>Wheel Set</p>  <p>FTX9461B (Black)</p> <p>FTX9461Y (Yellow)</p>	<p>Shock Set</p>  <p>FTX9462</p>	<p>Drive Gear(14T)</p>  <p>FTX9463</p>	<p>Solid axle bush W/Main Gear(38T)</p>  <p>FTX9464</p>
<p>RC370 Motor with Motor Gear Set</p>  <p>FTX9465</p>	<p>Battery/Battery Velcro</p>  <p>FTX9466</p>	<p>ESC / 25A</p>  <p>FTX9467</p>	<p>Servo 17g</p>  <p>FTX9468</p>
<p>USB Charger</p>  <p>ET0226D</p>	<p>Radio/ Receiver</p>  <p>FTX9470</p>	<p>LED Front Headlight Set (Ranger version only)</p>  <p>FTX9472</p>	<p>LED Front and Rear Steering Light</p>  <p>FTX9473</p>



FTX OUTBACK FURY XC & RANGER XC PARTS LISTING

Spare Part

<p>A-Snorkel, B-Light Mount, C-Front Grill Set D-Rearview Mirrors, E-Spare Wheelstands</p>  <p>Screws; 3x8x1P Screws; 2x6x10P Screws; 2x8x2P</p> <p>FTX9474 (Ranger version only)</p>	<p>Roof rack & Roll cage</p> <p>Screws; 2x6x4P Screws; 2x8x6P</p>  <p>(Ranger version only)</p> <p>FTX9475</p>		
<p>FTBB35-Ball Bearings</p>  <p>(7*11*3)</p>	<p>FTBB12- Ball Bearings</p>  <p>(4*8*3)</p>	<p>FTBB120- Ball Bearings</p>  <p>(5*10*4)</p>	<p>FTX8200 Ball Stand Ø 4.0</p> 
<p>FTX9480 – Ball Head</p> 	<p>FTX9481- Round Head Screw M2.5*8</p> 	<p>FTX9484 - Button Head Screw M2.5 x 7</p> 	<p>FTX8213-Buttonhead Screw M2*6</p> 
<p>FTX8215-Buttonhead Screw M2*14</p> 	<p>FTX8216-Buttonhead Screw M2*20</p> 	<p>FTX6879-Cap Head Hex Machine Screw M3*6</p> 	<p>FTX9482-Buttonhead Screw M2*10</p> 
<p>FTX8221-Buttonhead Screw M2*27</p> 	<p>FTX8207-Countersunk Screw M2*8</p> 	<p>FAST212BK-Body Clip</p> 	<p>A-Nylon Nuts M2x4P, B-Nylon Nuts 4x4P, C-Screw Set M3x2x2P</p>  <p>D-E-Clips M4x4P</p>
<p>FTX9477C-PC body clear FTX9477G-PVC body green</p> 	<p>FTX9476Y – PVC Body – Yellow FTX9476R – PVC Body – Red FTX9476B – PVC Body – Blue FTX9476C – PC – Clear</p>  <p>(Ranger Pick Up Body version)</p>		



FTX OUTBACK FURY XC EXCLUSIVE PARTS LISTING

<p>A-Front Light mount B-Rear Body BumperSet C-Grill Set D-Rearview Mirrors E-Tool Box F-Fuel Cap G-Handle</p> <p>FTX9488</p>	<p>Front & Rear Bumper</p> <p>FTX9487</p>	<p>PVC body</p> <p>FTX9486Y Yellow FTX9486R Red FTX9486W White FTX9496C Clear Lexan</p>
<p>LED Front Headlight Set</p> <p>FTX9485</p>	<p>Foot Pedal</p> <p>FTX9489</p>	<p>Receiver Wire Plug Adaptors (3pc)</p> <p>FTX9941</p>

OPTION PARTS

<p>FTX9495-Wheel Hex with Pin (AL.)</p>	<p>FTX9491-Motor Mount (AL.)</p>	<p>FTX9492-Bodyshell mounting plate (AL.)</p>	<p>FTX9493-Shock Set (AL.)</p>
<p>FTX9494-Steering Link (AL.)</p>	<p>FTX9478 - LED Lights (Ranger version)</p>	<p>FTX9490-Front Hub Set (AL.)</p>	
<p>FTX9496 - Front CVD Shafts</p>			



FTX OUTBACK FURY XC & RANGER XC EXPLODED PARTS DIAGRAM

Front Drive Assembly

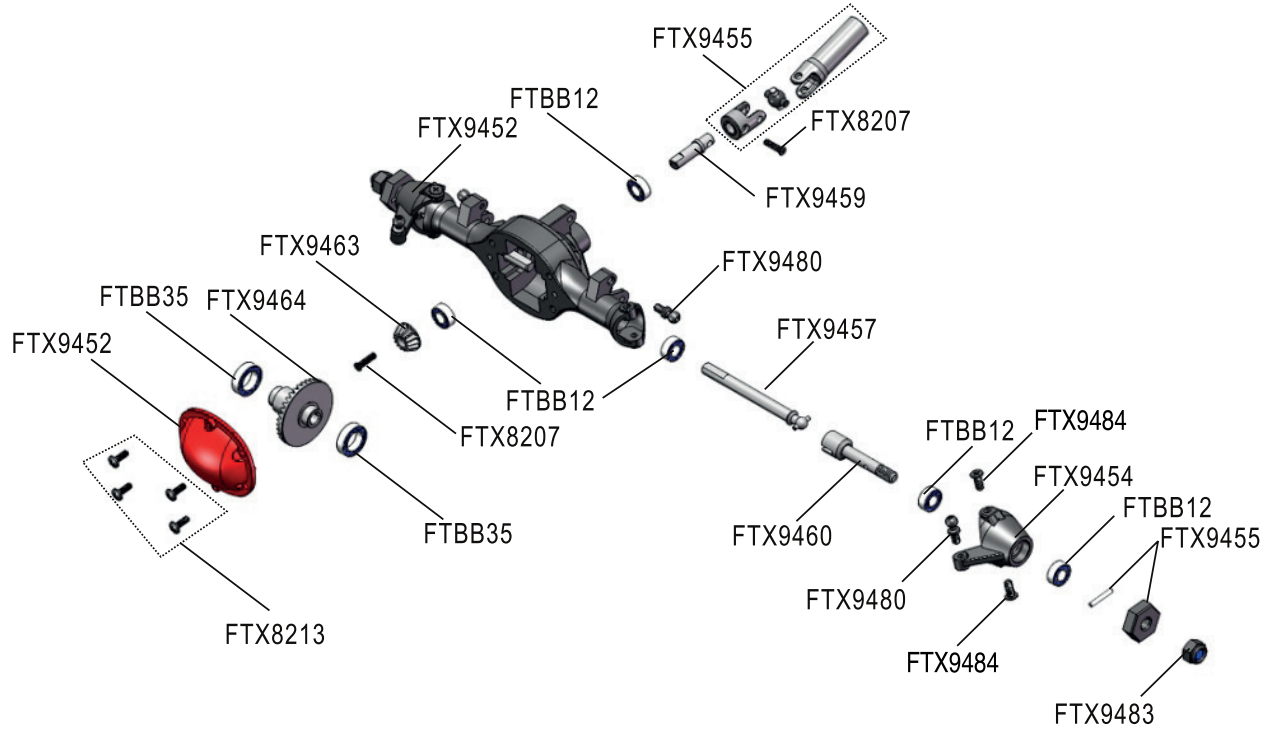

Rear Drive Assembly

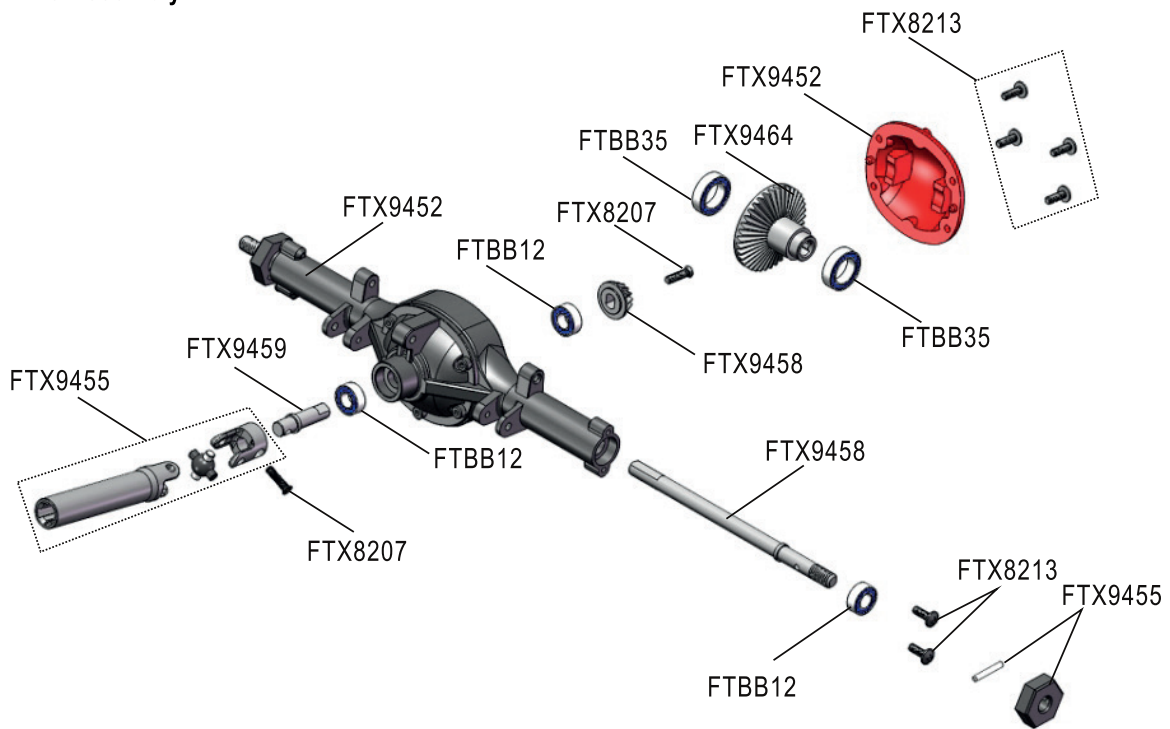



FTX OUTBACK FURY XC & RANGER XC EXPLODED PARTS DIAGRAM

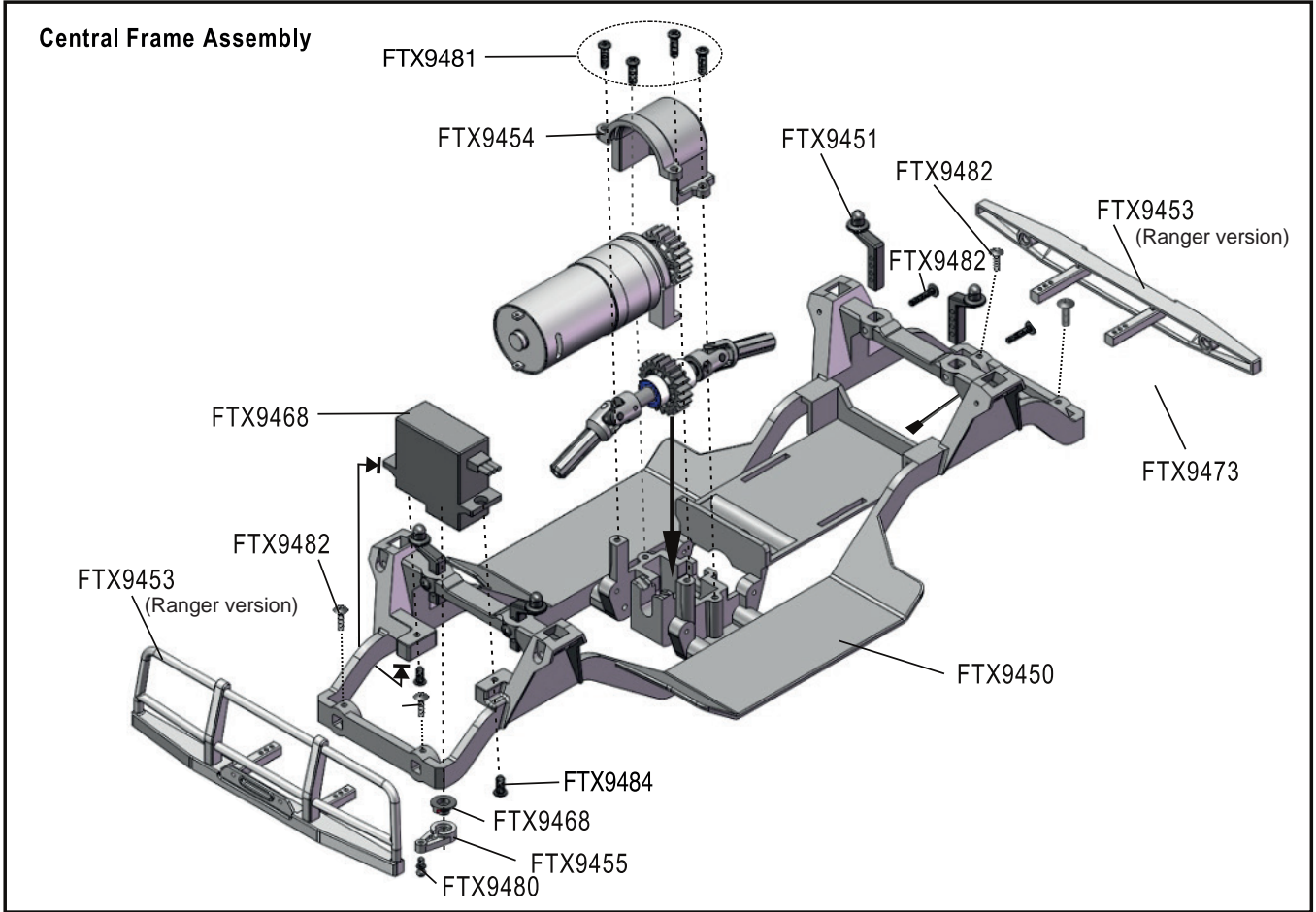
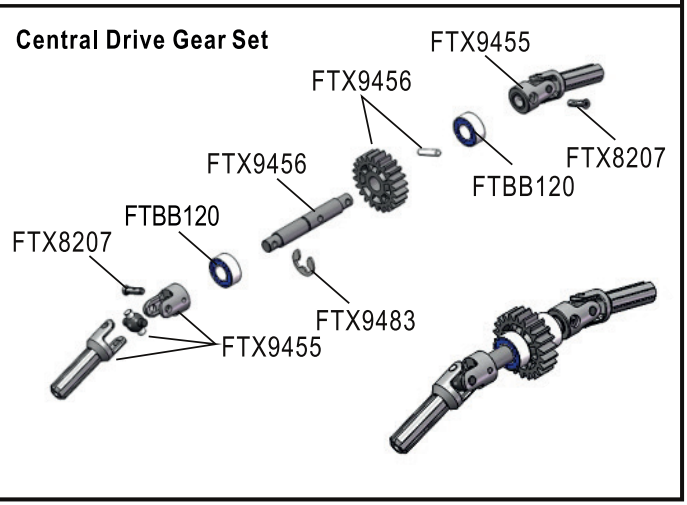
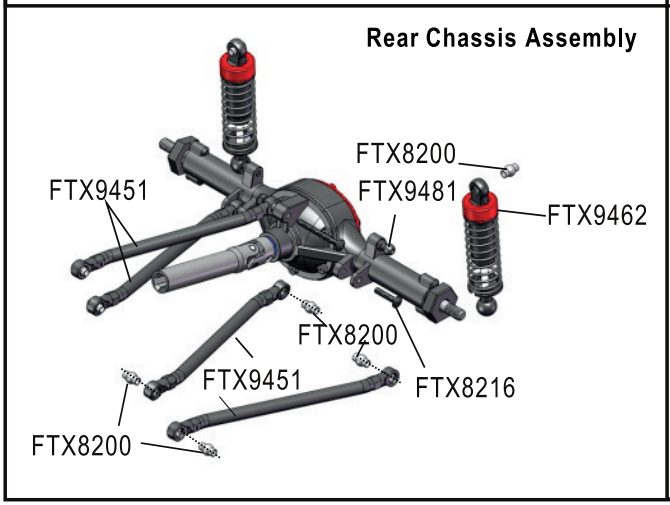
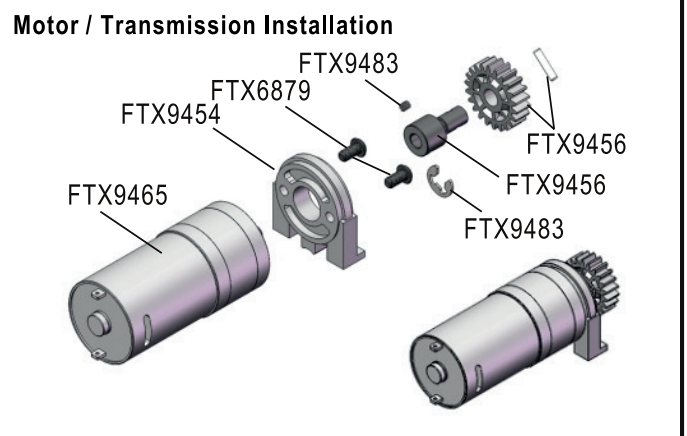
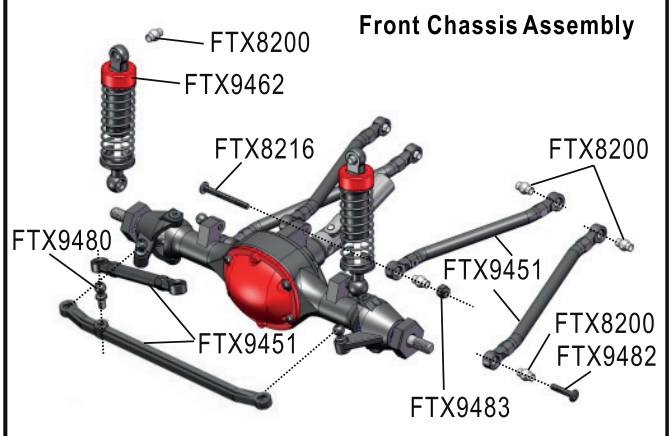



FTX OUTBACK FURY XC & RANGER XC EXPLODED PARTS DIAGRAM

Central Frame Assembly (Ranger version illustrated)

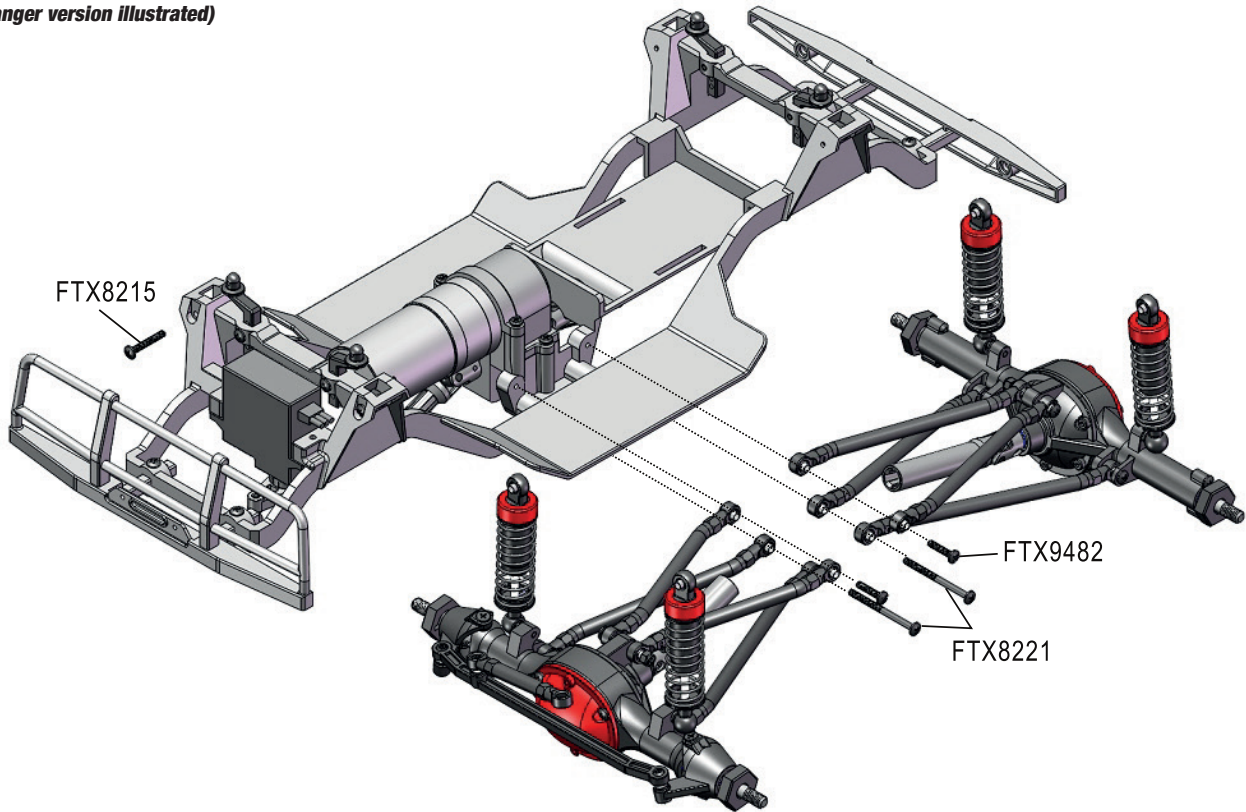

Electric Components / Wheel Assembly (Ranger version illustrated)

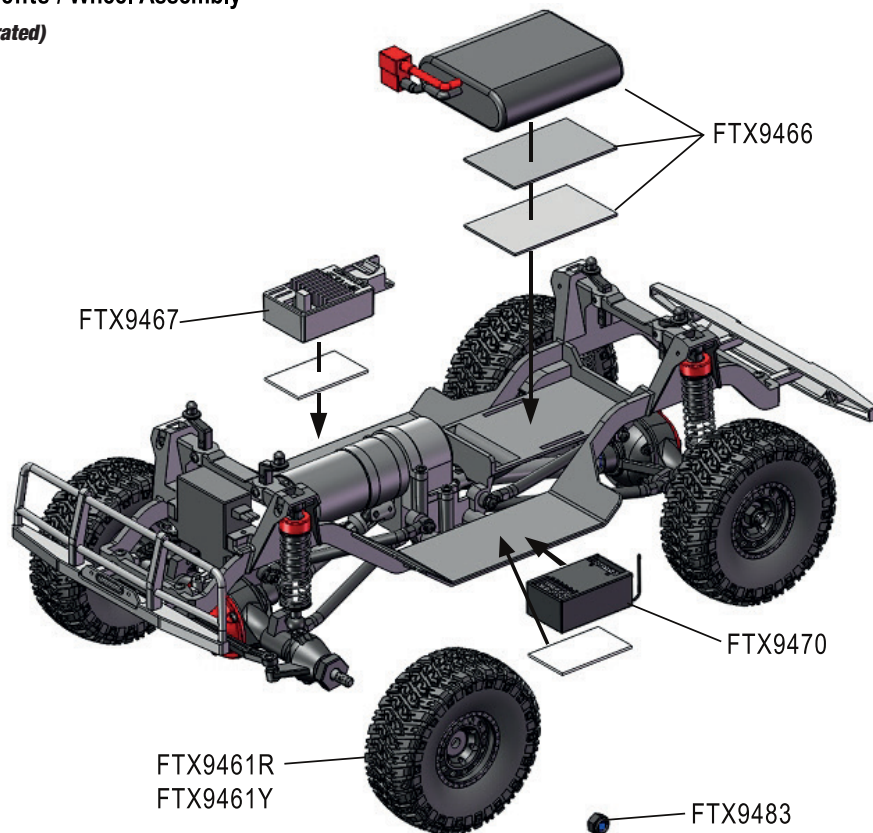



FTX OUTBACK RANGER XC EXPLODED PARTS DIAGRAM

Bodyshell Accessories Assembly

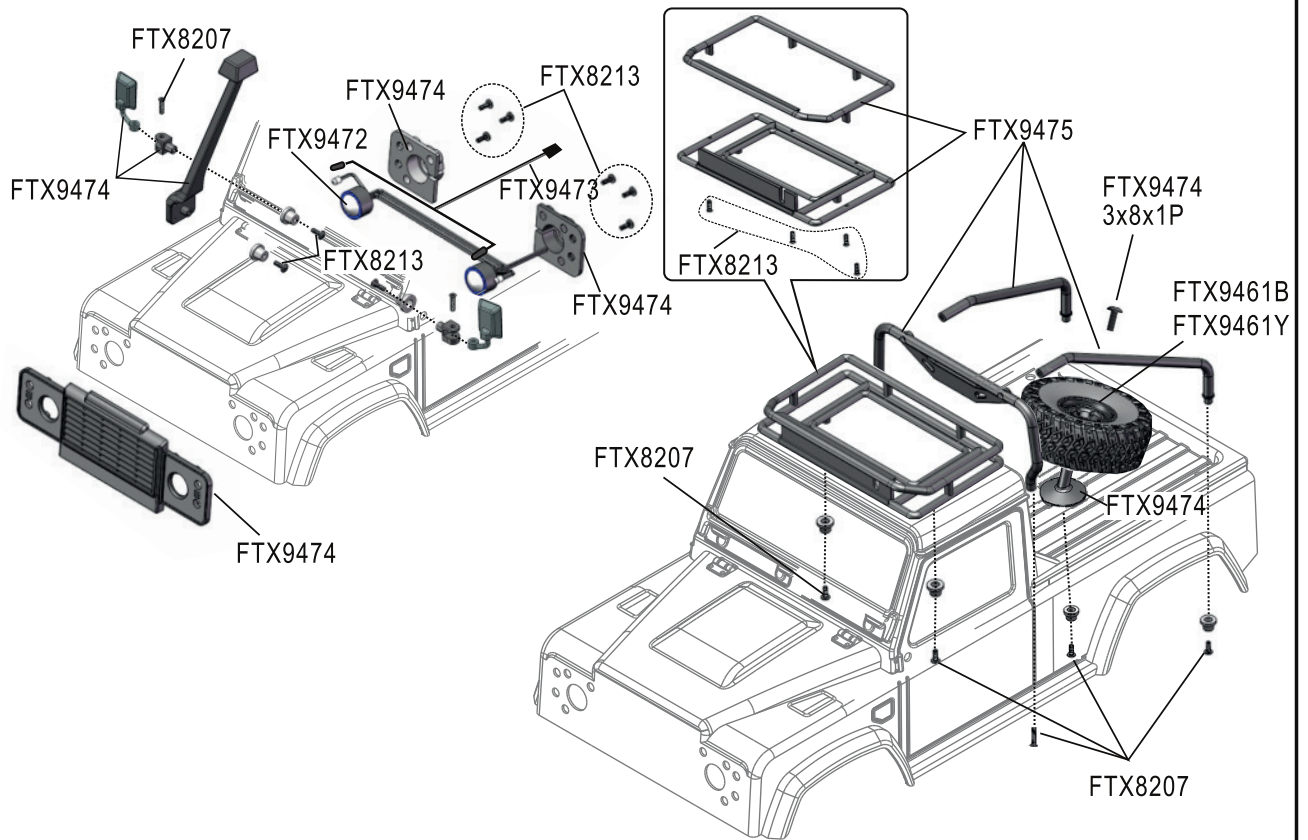

Bodyshell Assembly

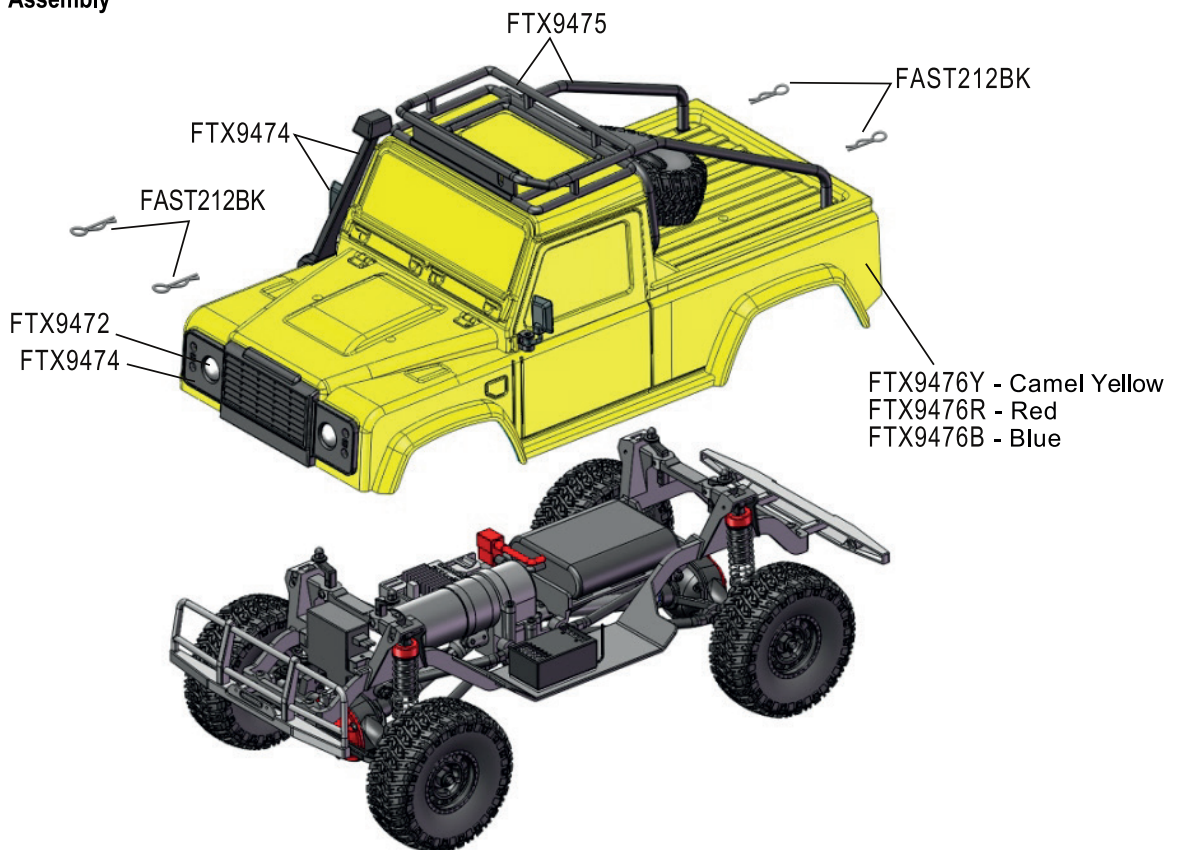



FTX OUTBACK FURY XC EXPLODED PARTS DIAGRAM

Outback Fury XC Bodyshell Accessories Assembly

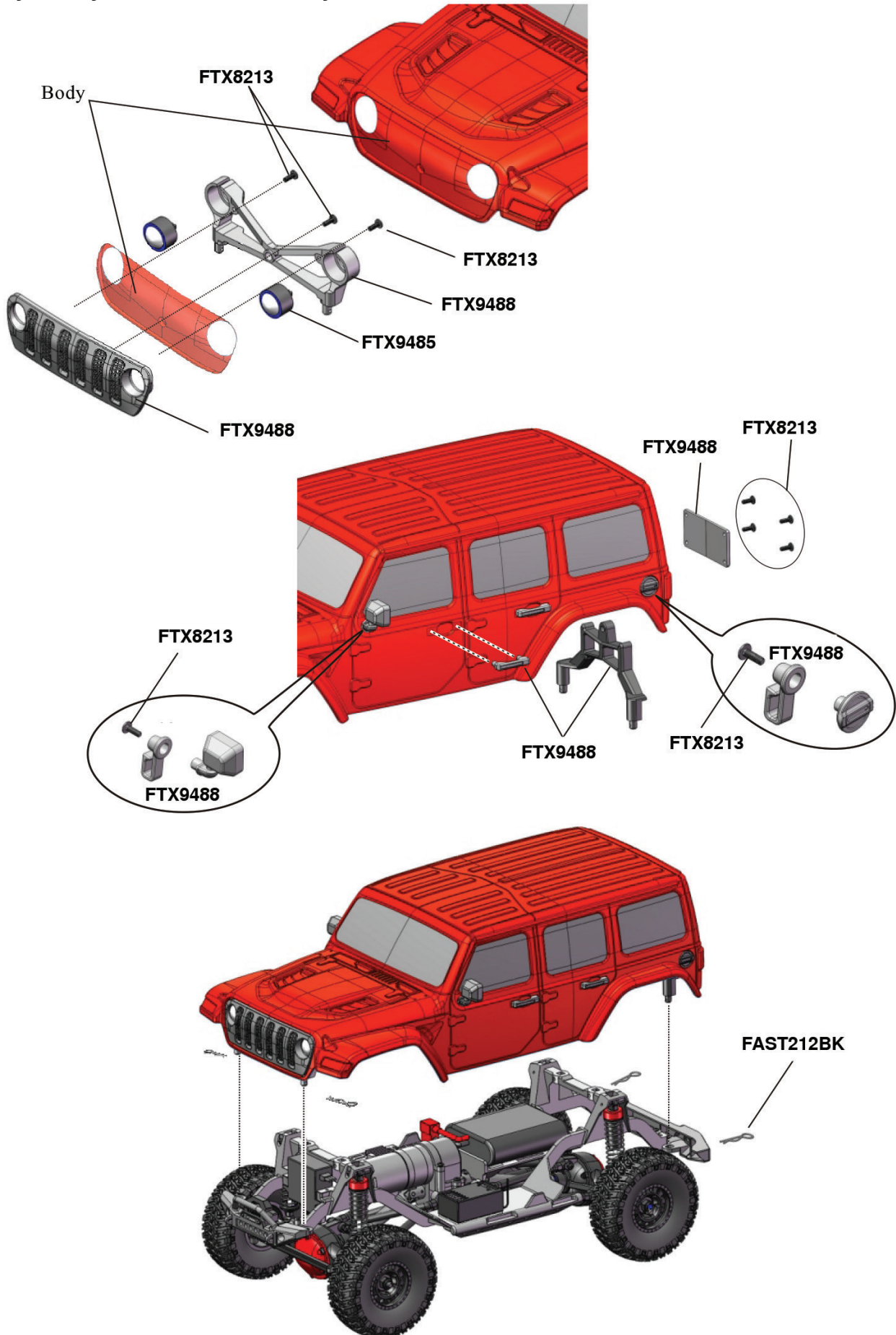



www.ftx-rc.com

FTX is an exclusive brand of CML Distribution, Saxon House, Saxon Business Park,
Hanbury Road, Bromsgrove, Worcestershire, B60 4AD England.
E-mail: info@ftx-rc.com